

**AN OVERVIEW OF HYDROGEN PRODUCTION FROM
KRW OXYGEN-BLOWN GASIFICATION WITH CARBON DIOXIDE RECOVERY ***

by

Richard D. Doctor, Norman F. Brockmeier, John C. Molburg,
P. Thimmapuram, and Karen L. Chess,**

Argonne National Laboratory
Energy Systems Division/Bldg. 362
9700 S. Cass Ave.
Argonne, IL 60439-4815

The submitted manuscript has been created by the University of Chicago as Operator of Argonne National Laboratory ("Argonne") under Contract No. W-31-109-ENG-38 with the U.S. Department of Energy. The U.S. Government retains for itself, and others acting on its behalf, a paid-up, nonexclusive, irrevocable worldwide license in said article to reproduce, prepare derivative works, distribute copies to the public, and perform publicly and display publicly, by or on behalf of the Government.

August 2000

Submitted for publication in the Proceedings of the Aspen Global Climate Change Institute, July 22-28, 2000 Aspen, CO

*Work supported by the U.S. Department of Energy, Office of Fossil Energy, under Contract No. W-31-109-ENG-38.

**Current address: Fuel Tech, 1001 Frontenac Rd., Naperville, IL 60563-1746

AN OVERVIEW OF HYDROGEN PRODUCTION FROM KRW OXYGEN-BLOWN GASIFICATION WITH CARBON DIOXIDE RECOVERY

All the process elements are commercially available to operate coal gasification so that it can produce electricity, hydrogen, and carbon dioxide while delivering the same Mw quantity of power. To judge the overall impact of such a scheme, a full-energy cycle must be investigated (Fig. 1). Fig. 2 shows an oxygen-blown KRW integrated gasification combined-cycle plant producing hydrogen, electricity, and supercritical-CO₂. This system was studied in a full-energy cycle analysis extending from the coal mine to the final destination of the gaseous product streams [Doctor, et al. 1996, 1999] based on an earlier study [Gallaspy, et al., 1990]. Here we report the results of updating these studies to use current turbine performance.

A location in the mid-western United States was chosen 160-km from Old Ben #26 mine which ships 3,866 tonnes/day of Illinois #6 coal by diesel locomotive. Three parallel gasifier trains, each capable of providing 42% of the plant's 456 MW nominal capacity use a combined total of 3,488 tonnes/day of 1/4" prepared coal. The plant directly produces a net 134 MW of power and 3.71×10^6 nm³/day of a hydrogen stream containing all the inert Argon, but otherwise at 99.999% purity. This hydrogen product is sent 100 km by pipeline at 34 bars where it is used to generate 330 MW of additional power, for a net production of 455 MW when all the losses in the cycle are accounted for accurately. The plant also produces 3.18×10^6 nm³/day of supercritical CO₂ at 143 bars, which is sequestered in enhanced oil recovery operations 500 km away.

A 100-km hydrogen pipeline design was prepared and costs were estimated for a high purity hydrogen flow of 3.71×10^6 nm³/day through a 343 mm pipe at 30 bar. There appears to be no economic justification for going to higher pipeline pressures and an internal study of the costs for delivering energy as methane vs. energy as H₂ showed a 13% advantage for methane at 500 psi rising to a 46% advantage at 800 psi. Economic assumptions were for an availability of 95% and capital recovery of 12% to yield transmission costs of 0.171 \$/Mscf; 0.564 \$/GJ. It is very important to observe that the high costs of a dedicated pipeline dictate the need for high availabilities.

What is critical to note is that separating the hydrogen for fuel cell and then using an optimistic, but technically achievable, performance efficiency yields an impressive gain in overall process efficiency. This gain offsets the losses in efficiency from the recovery of CO₂. Hence, compared against a base case with no CO₂ recovery, consumers are delivered the identical amount of power from a given input of coal.

Carbon dioxide as a supercritical product (143 bar) can be recovered from coal gasification and power production. Where there is an enhanced oil recovery market, this actually is profitable. The need for high-pipeline utilization is critical. Hydrogen can be recovered at high purity (99.999%) for sale from coal gasification, however the need for high pipeline-utilization is critical. Pressures of 35 bar are optimal. Fuel-cell conversion efficiencies need to approach 77% to match the base-case output. At present, solid-oxide fuel cell efficiencies are 53-58%; while alkaline fuel cell efficiencies are near 70%.

For this study, the three major greenhouse gases CO₂, CH₄ and N₂O were followed throughout the cycle. A CO₂ emission rate of 1 kgCO₂/kWh was assumed for power purchases outside the fence of the IGCC plant to estimate the impact of these emissions (A summary of this appears in Table 1). While the base case IGCC plant with no modifications is nearly 28% lower in CO₂ emissions than current U.S. grid emission, a reduction from 0.72 kgCO₂/kWh down to 0.16 kgCO₂/kWh is technically feasible with this scheme. This low greenhouse impact strategy is not without a high economic cost, and the uncertainty about this impact is linked to uncertainty about the sales value of hydrogen and the future disposal charges for CO₂.

**Table (1) Materials flow for O₂-blown IGCC
Glycol CO₂ and H₂S recovery; PSA hydrogen recovery; turbine topping cycle; solid oxide
fuel cell @ 65%
Basis: Electric power delivery 100 km from
station**

	Power	CO ₂	CH ₄	N ₂ O
--	-------	-----------------	-----------------	------------------

	nm ³ /d	tons/c	kg/h	MW	kg/h	kg/h	kg/h
MINING AND TRANSPORT							
Coal methane emissions						566	
Mining operations & preparation				-2.61	2,614		0.00003
Transport by rail - 161km				-0.21	905		0.66265
Subtotal				-2.82	3,520	566	0.66267

POWER PLANT							
Coal preparation (0" x 1/4")		3,845	145,341	-0.85			
O ₂ by cryogenic separation	8,937,000	2,347	88,717	-29.29			
Steam from heat recovery steam generator			17,254				
Gasifier island				-2.90			
Solid waste		492	18,598				
Sulfur		78	2,948				
SO ₂ (gasifier only)		6.92	262		6,157		unknown
Glycol circulation				-5.80	320,383		
Glycol refrigeration				-4.50			
Power recovery turbines				3.40			
CO ₂ compression to pipeline (143 bar)	3,178,000			-17.30	-260,055		
H ₂ PSA purification to pipeline (31 bar)	3,710,000			-3.18			
H ₂ cryo-storage for pipeline				-0.92			
Power island				-3.09			
Miscellaneous (5%)				-3.07			
Subtotal				-67.50	66,485		0 unknown
Power - gas turbine				501.78			
Power - air compressor and losses				-347.77			
Power - steam turbine				47.80			
GROSS Power Subtotal				201.81			
NET Power				134.30			

CO₂ PIPELINE AND SEQUESTERING							
	3,178,000				260,055		
Pipeline booster stations				-1.64	1,637		0.00002
Geological reservoir (1% loss)					-257,454		
Subtotal				-1.64	4,238		0 0.00002

H₂ PIPELINE OUTLET (21 bar)							
	3,710,000						
H ₂ 3-stage SOFC (65% of 460.0MW)				299.00			
Steam Generator (85% of 36.8MW)				31.28			
Subtotal				330.28	0	0	0.00000

POWER TRANSMISSION LOSS-3.5% **-4.70**

NET ENERGY CYCLE	0.163	kg CO₂/kWh	455.42	74,242	566	0.66269	
NET ENERGY CYCLE -Base Case	0.723	kg CO₂/kWh	456.46	330,060	566	0.66267	

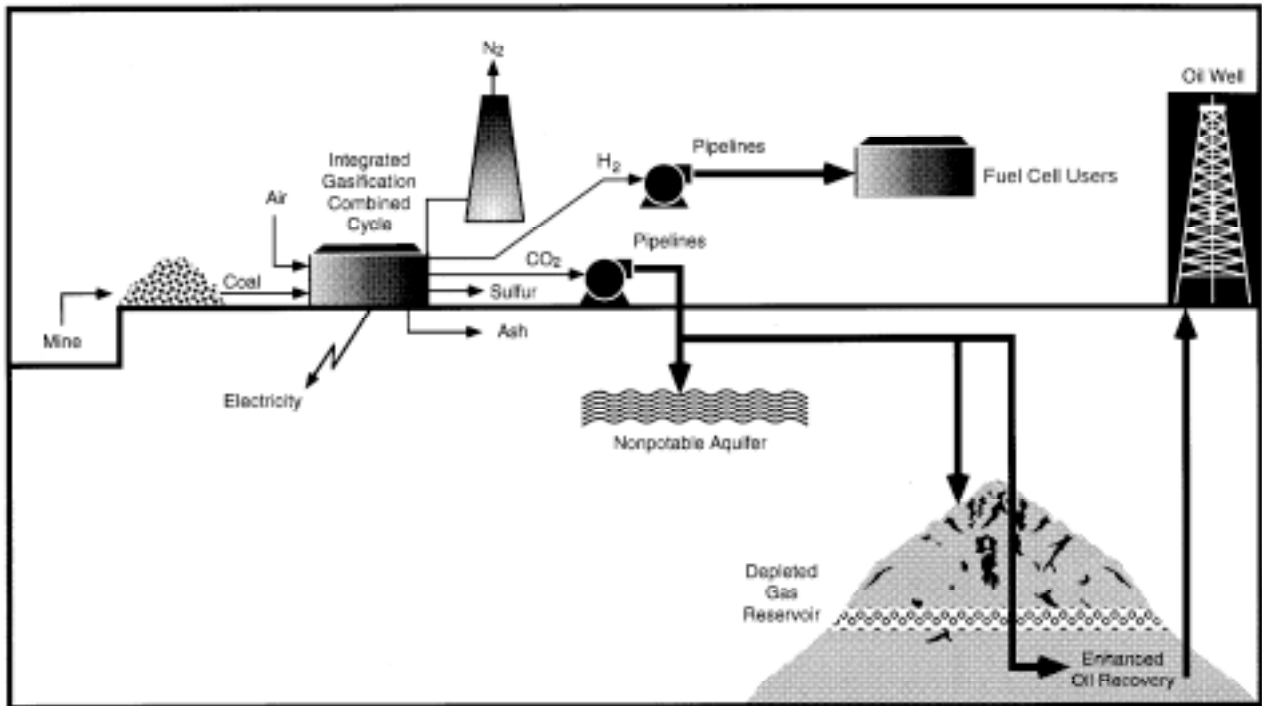

Fig. 1 Full energy cycle for the production of electricity, hydrogen, and carbon dioxide

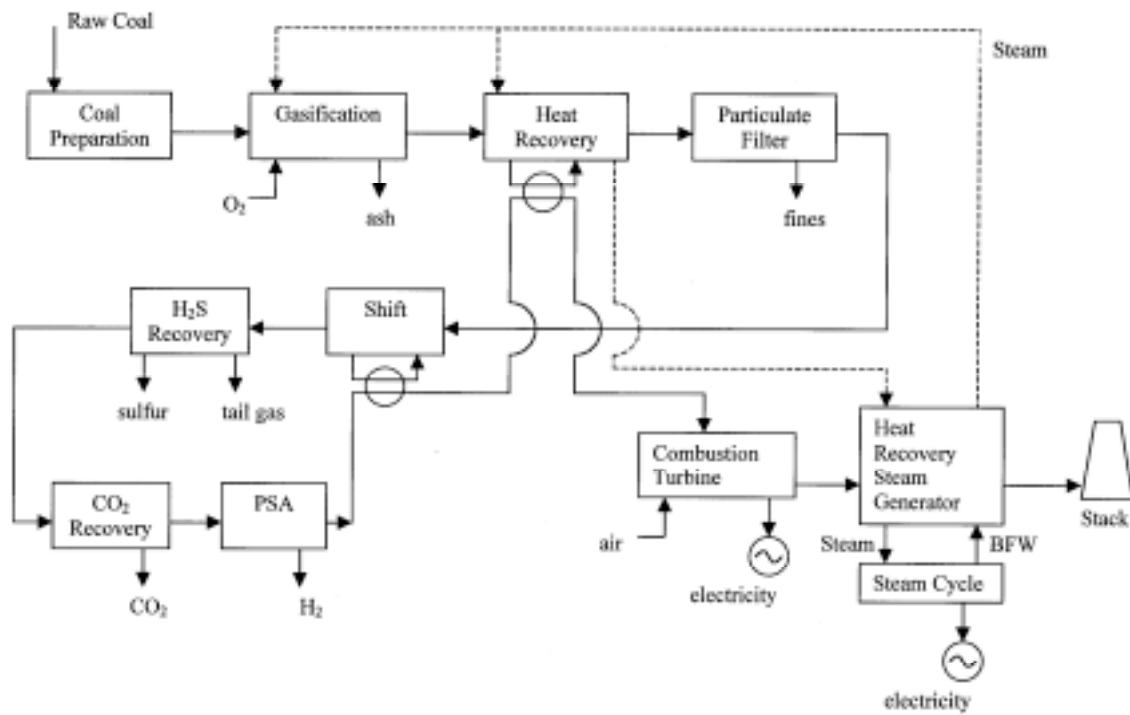

Fig. 2. Integrated Gasification Combined-Cycle Producing Electricity, CO₂ and H₂

ACKNOWLEDGMENTS

This work is supported by the U.S. Department of Energy Fossil Energy Program at the Federal Energy Technology Center, through contract W-31-109-Eng-38; contract managers, Gary Stiegel and Sean Plasynski. Special thanks for the support and encouragement from Perry Bergman.

REFERENCES

1. Gallaspy, D.T., et al., 1990. Southern Company Service's Study of a KRW-based GCC Power Plant, EPRI GS-6876, Electric Power Research Institute, Palo Alto, CA.
2. Doctor, R.D., Molburg, J.C., and Thimmapuram, P.R., 1996. KRW Oxygen-Blown Gasification Combined Cycle: Carbon Dioxide Recovery, Transport, and Disposal, ANL/ESD-34, Argonne National Laboratory, Argonne, IL.
3. Doctor, R.D., K.L. Chess, N.F. Brockmeier, J.C. Molburg, P.R. Thimmapuram, *Hydrogen Production and Carbon Dioxide Recovery from KRW Oxygen-Blown Gasification*, Greenhouse Gas Control Technologies, Proceedings of the 4th International Conference, Interlaken, Switzerland, 30 August - 2 September 1998, B. Eliasson, P. Riemer, A. Woukan, eds., Elsevier, Oxford (1999) p.65-70.